



DDRC-GRMS-E

Multi-protocol Switching Room Controller

Fully networked relay control solution

The Philips Dynalite DDRC-GRMS-E controller is a compact, versatile room automation and energy management solution with bridging functionality between the Ethernet LAN and connected DyNet devices. Bespoke pre-configuration allows deployment without the need for commissioning software.

Incorporating switching relays and DMX for dimming and color control, every aspect of this device has been designed to be feature-rich and cost-effective.

DDRC-GRMS-E

Room controller and Ethernet bridge in one compact device

- **Single box solution** – Compact design allows for small installation footprint and reduced cabling for a simpler and faster installation.
- **Inbuilt Ethernet port** – Directly connecting to a site's Ethernet LAN, the device can securely report its status and pass network messages via the Dynalite PDDEG-S*.
- **Pre-programmed** – Can be preloaded with a bespoke configuration to immediately meet the project's needs from the moment it powers up.
- **Powerful processor** – The internal processor allows the device to perform advanced scripted functions and provide automated intelligent responses to multiple inputs.
- **Mixture of switching relays** – Supports a combination of different relay ratings and types for a perfect blend of performance and cost-effectiveness.
- **18 dry contact inputs** – Allows simple integration with third-party devices and systems.
- **64 channel DMX output** – Adds color and dimming control for a touch of theatrics.
- **UL924 Input** – Integrates seamlessly with compatible emergency systems.
- **Four 12 V digital outputs** – Designed to drive room status indicator LEDs in common cathode configuration, and trigger additional devices such as doorbells.
- **300 mA DyNet output** – Directly support the requirements of DyNet devices without the need for an additional network power supply.
- **Unique LAN addressing** – Two banks of DIP switches allow the installer to manually set the device's network identification.

* Each PDDEG-S supports encrypted communication with up to 25 controllers.

Dimensions

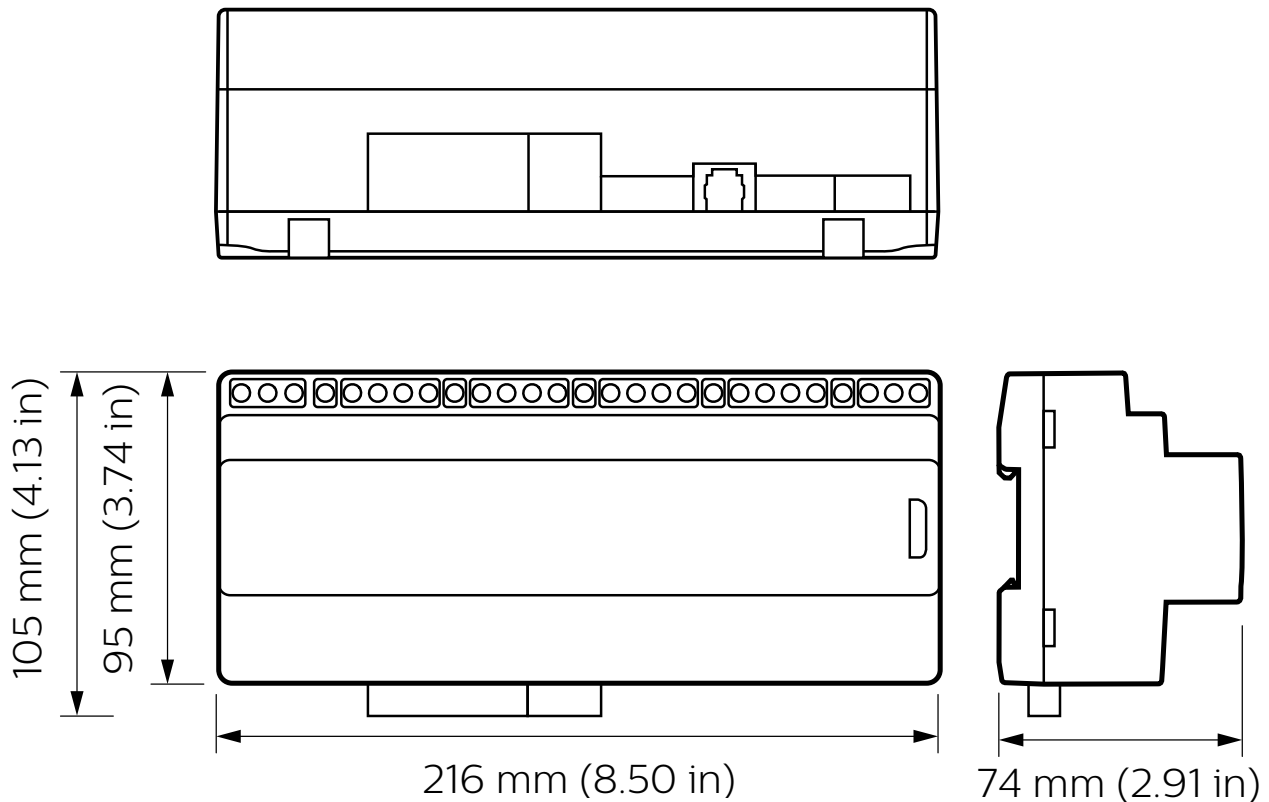

Specifications

Due to continuous improvements and innovations, specifications may change without notice.



DDRC-GRMS-E
Multi-protocol Switching Room Controller

Electrical

Supply Type	Single-phase*
Supply Voltage	100-240 VAC
Supply Current	0.25 A
Outputs	13 x switched outputs (See diagram below)
DyNet DC Output Voltage	12 VDC
DyNet DC Output Current	300 mA
Digital Output Voltage	12 VDC
Digital Output Current	2 mA
Dry Contact / UL924 Input Voltage**	12 VDC (max)
Dry Contact / UL924 Input Current**	0.5 mA (max)
IEC Overvoltage Category	III

Control

Serial Ports	1 x RS485 1 x Ethernet (10/100 baseT) 1 x DMX
Supported Protocols	DyNet DMX Tx TCP/IP (TCP, UDP), IPv4, IPv6
Dry Contact Inputs	18
DMX Tx Channels	64
UL924 Inputs	1
Digital Outputs	4
Diagnostic Functions	Device online/offline status
User Controls	1 x service switch 2 x 8-bit DIP switches
Indicators	1 x service LED 2 x Ethernet activity LED

* **NOTE:** ALL inputs must be powered on the same phase.

** SELV/Class 2, no galvanic isolation on Dry Contact/UL924 inputs

Physical

Dimensions (H x W x D)	105 x 216 x 74 mm (4.13 x 3.74 x 2.91 in)
Packed Weight	0.67 kg (1.48 lb)
Construction	Polycarbonate DIN-rail enclosure (12 unit)
Serial Ports	1 x 5-way pluggable screw terminal 1 x RJ45
Serial Port Conductor Size	2.5 mm ² (#12 AWG) (max)
Digital Outputs	1 x 5-way pluggable screw terminal
DMX/UL924	1 x 5-way pluggable screw terminal (3/2)
Dry Contact Input Terminals	2 x 12-way pluggable screw terminal
Digital Output, DMX/UL924, Dry Contact Input Terminal Conductor Size	1.5 mm ² (#16 AWG) (max)
Supply Terminals	3 x screw terminal Line, Neutral, Earth
Supply Terminal Conductor Size	6 mm ² (#10 AWG) (max)
Output Terminals	24 x screw terminal
Output Terminal Conductor Size	6 mm ² (#10 AWG) (max)

Environment***

Operating Temperature	0° to 50°C ambient (32° to 122°F)
Storage/Transport Temperature	-25° to 70°C ambient (-13° to 158°F)
Humidity	0 to 90% non-condensing
IEC Pollution Degree	II

Compliance

Certification	CE, RCM, UL, FCC, ICES, UKCA, RoHS
---------------	------------------------------------

*** For indoor installation only

Example Output Diagram

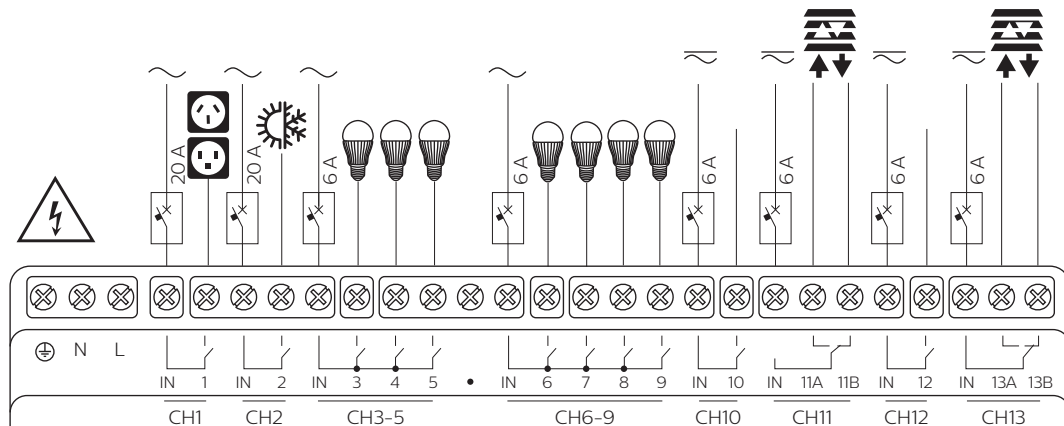

Electrical

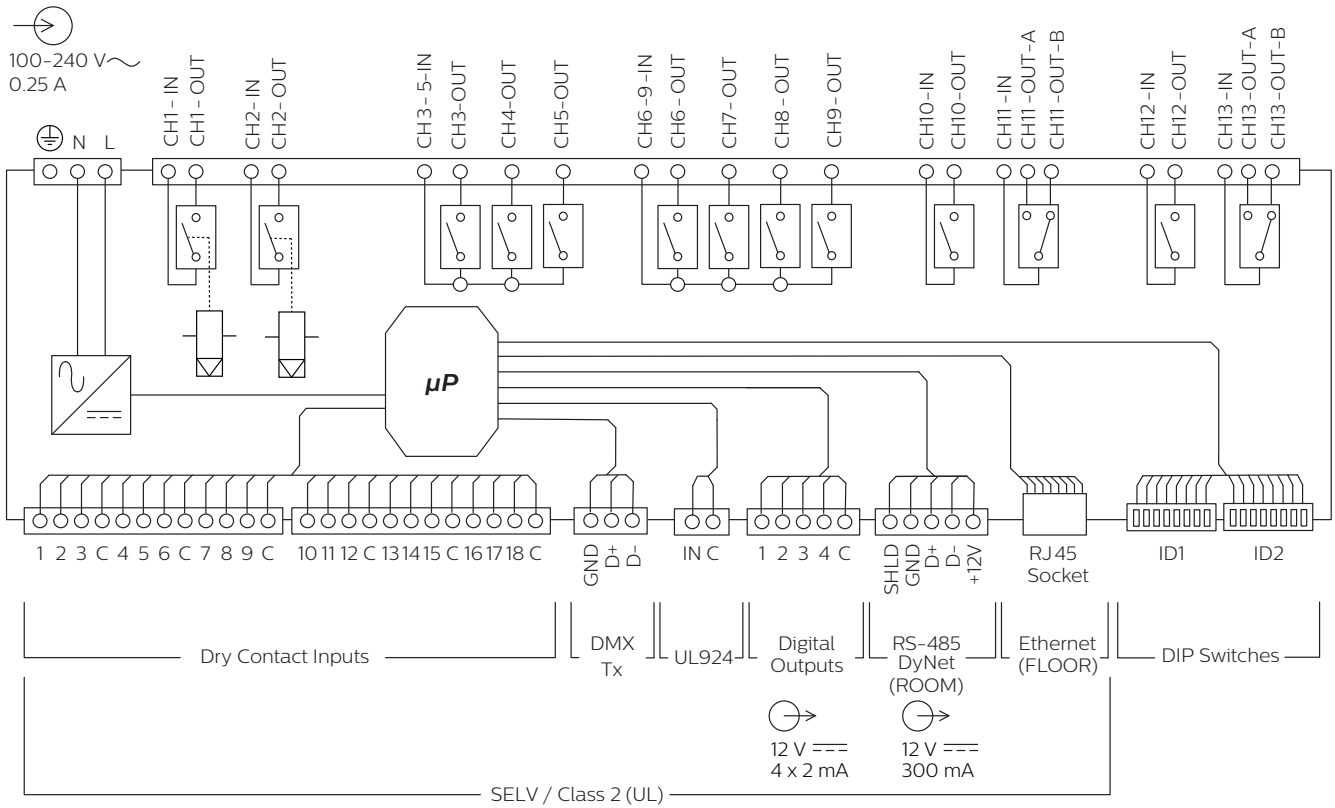

Output Channel Ratings

Load Type	Maximum Rating per Output				
	CH1, CH2	CH3 - CH5 CH6 - CH9	CH10, CH12	CH11A, CH13A	CH11B, CH13B
General Use	20 A, 240 VAC	4 A, 240 VAC	6 A, 240 VAC	6 A, 240 VAC	6 A, 240 VAC
Resistive	20 A, 240 VAC	4 A, 240 VAC	6 A, 240 VAC 1 A, 24 VDC	6 A, 240 VAC 1 A, 24 VDC	6 A, 240 VAC 1A, 24 VDC
Incandescent	15 A, 120 VAC 6 A, 240 VAC	4 A, 240 VAC	4 A, 240 VAC	4 A, 240 VAC	X
Electronic Ballast	15 A, 120 VAC 6 A, 240 VAC	2 A, 120 VAC 0.8 A, 240 VAC	2 A, 120 VAC 0.8 A, 240 VAC	2 A, 120 VAC 0.8 A, 240 VAC	X
Motor	9.8 FLA (½ HP), 120 VAC 8 FLA (1 HP), 240 VAC	X	5.2 FLA (½ HP), 120 VAC 4.3 FLA (¾ HP), 240 VAC	5.2 FLA (½ HP), 120 VAC 4.3 FLA (¾ HP), 240 VAC	X
TV Rating	TV-8, 240 VAC	TV-8, 120 VAC	TV-8, 120 VAC	TV-5, 240 VAC	X
Inrush Current	320 A	60 A	60 A	90 A	X

Maximum Group Load	CH3 - CH5	CH6 - CH9	DEVICE TOTAL
	6 A	6 A	76 A

Ordering Code

Product

DDRC-GRMS-E

Philips 12NC

913703334009

© 2024 Signify Holding.

All rights reserved. Specifications are subject to change without notice. No representation or warranty as to the accuracy or completeness of the information included herein is given and any liability for any action in reliance thereon is disclaimed. Philips and the Philips Shield Emblem are registered trademarks of Koninklijke Philips N.V. All other trademarks are owned by Signify Holding or their respective owners.



www.dynalite.com

Revision 10 – 2024-01-17