

SpaceLogic C-Bus Voltage Free Relays

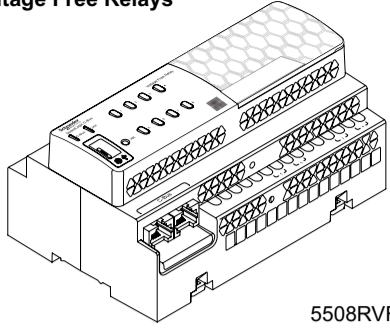

5508RVF



1

Load Type ¹	Maximum Load on any channel ²
LED (Self Ballasted Lamp)	400 W (230 V) 150 W (110 V)
Incandescent Lamps	10 A
Fluorescent Lamps (Externally Ballasted Lamps)	16 AX
Inductive Loads (Power Factor ≥ 0.6)	10 A
Motors	5 A M.30

¹ According to IEC 60669-2-1 AS 60669.2.1

² Derating is applicable for multiple channels, refer User manual

2

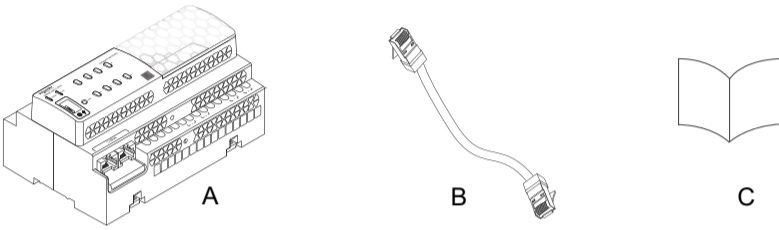

3

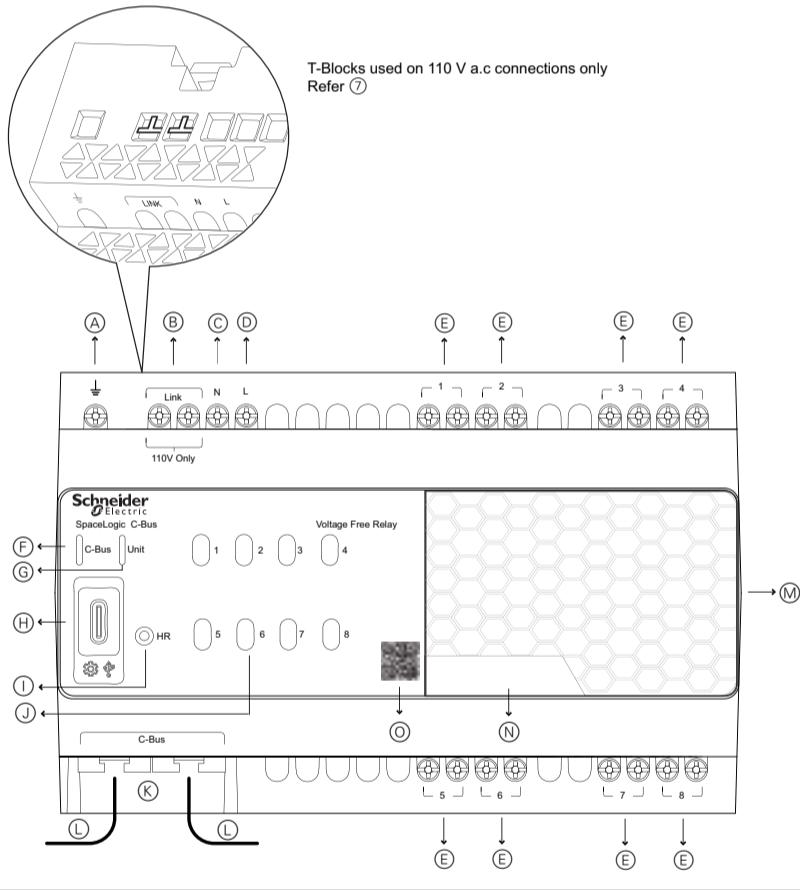

4

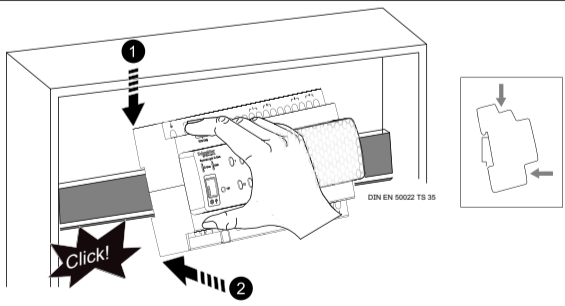

5

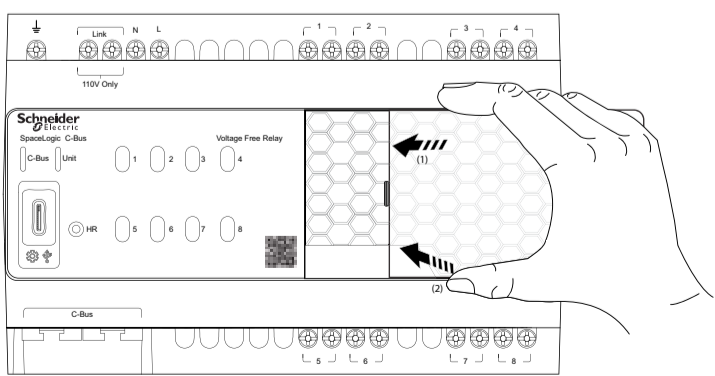

en SpaceLogic C-Bus 8 Channel Voltage Free Relay

Introduction

The SpaceLogic C-Bus Relays are voltage free relays that enable the control of electrical loads.

Product Range

Catalog Number	Description
5508RVF	Voltage Free Relay, SpaceLogic C-Bus, DIN rail mount, 8 channel, inbuilt switchable C-Bus power supply

For Your Safety

⚠ DANGER

HAZARD OF ELECTRIC SHOCK, EXPLOSION, OR ARC FLASH

- This product must be installed and serviced by appropriately qualified and/or licensed professional in accordance with the local wiring rules.
- Isolate the electrical supply before doing any work on the product.
- Ensure that the product has been correctly installed and tested for safe operation before reconnecting the electrical supply.
- Do not use this product for any other purpose than specified in this instruction.
- Pay attention to the specifications and wiring diagrams related to the installation.
- Do not attempt to open the product casing or perform any action on the internal components of the product.

Failure to follow these instructions will result in death or serious injury.

⚠ WARNING

INCORRECT C-BUS CABLE INSTALLATION

The C-Bus network cabling is classified as Separated Extra-Low Voltage (SELV) wiring. To maintain this requirement, the approved C-Bus cable must be used.

- Ensure that adequate separation and/or segregation of the C-Bus cable from other wiring (for example Low Voltage wiring) is maintained throughout the entire installation.
- Ensure the C-Bus network cable is installed in accordance with the SELV wiring rules and regulations of the jurisdiction.

Failure to follow these instructions can result in death, serious injury, or equipment damage.

NOTICE

APPROPRIATE ACCESS CONTROL

To prevent the possibility of intentional or unintentional interference with the configuration or operation of the C-Bus installation, this equipment should be installed in a location with appropriate access control.

Failure to follow these instructions can result in equipment damage.

NOTICE

EQUIPMENT DAMAGE HAZARD

It is important to select the right location to install the C-Bus relay. Some considerations are listed below:

- For indoor use only.
- Use a location free of water, humidity, direct sunlight, and heavy dust.
- Make sure there is adequate ventilation, and the internal temperature rise is limited.

Failure to follow these instructions can result in equipment damage.

NOTICE

MEGGER TESTING

Megger testing is never to be performed on any cable while connected to the product as it could degrade the performance of the product and/or the network.

Failure to follow these instructions can result in equipment damage.

NOTICE

EQUIPMENT DAMAGE HAZARD

It is important to limit the mains voltage to the range specified. Additional external power surge protection devices should be used to enhance system immunity to power surges outside the specified range.

Overvoltage equipment such as the MAX-9 / Acti-9 is recommended to be installed at the switchboard.

Failure to follow these instructions can result in equipment damage.

NOTICE

EQUIPMENT DAMAGE HAZARD

Circuit protection on feeds to relay channels must have a trip current rating of no greater than 20A.

Failure to follow these instructions can result in equipment damage.

1 Compatible Loads

NOTICE

MAXIMUM LOAD RATINGS APPLY

Circuit protection on feeds to relay channels must have a trip current rating of no greater than 20A.

Failure to follow these instructions can result in equipment damage.

Derating*

The relay channel's load rating is determined by the temperature increase observed in a single channel when operated at full load, after completing the specified number of switching cycles.

When operating multiple channels at or near their maximum rated current, derating is necessary. This can be achieved by limiting the total current per unit or by controlling the temperature of the operating environment, specifically the air temperature immediately surrounding the relay. Refer ①, User Manual for further information. Regardless of channel load, the operating environment must always be maintained below 55 °C.

Note: The operating calorific values of the relay are provided in the User Manual. When selecting the equipment and enclosure, you must consider these values along with the total heat load of all equipment in the enclosure. This is necessary to ensure the operating environment does not exceed 55 °C.

2 Package Contents

3 About the Relay

- A Earth
- B Wire Link Terminal for 110 V
- C Neutral
- D Active Line
- E Load Connections
- F C-Bus Indicator
- G Unit Indicator
- H USB (Type-C) Connector
- I Hard Reset Button
- J Channel Button Indicators
- K C-Bus Connectors 2x RJ-45
- L C-Bus Network Cable
- M Transparent Removable Cover
- N Space for Labelling
- O QR code for product details and serial number

4 Mounting DIN Rail

The relay should only be installed horizontally on the mounting rails (type DIN EN 50022 TS 35) inside a distribution board.

5 Remove / Place Cover for Labelling

To remove, push the cover to the left side and lift the cover upwards supporting the sides of the cover. To place back the cover, refer illustration.

6 230 V Wiring

⚠ WARNING

EQUIPMENT DAMAGE HAZARD

Do not break T-Block terminal and/or insert a wire-link unless using the relay with 110 Vac unit supply voltage.

Failure to follow these instructions can result in death, serious injury, or equipment damage.

7 110 V Wiring

To use the relay with a 110 Vac unit supply, break the T-Block terminal using a screwdriver and connect a wire link between terminals ③ ④.

⚠ WARNING

EQUIPMENT DAMAGE HAZARD

While breaking the T-block in the terminal, be careful not to damage other terminal blocks.

Failure to follow these instructions can result in death, serious injury, or equipment damage.

C-Bus Network Connection

Connection to the C-Bus network is made via one of the RJ45 connectors. Use only C-Bus certified cable, which is identifiable by its pink sheath. For C-Bus cable, refer to catalogue numbers (5005C305B for solid cable and 5005C305BST for stranded cable). Pinouts and cable conductor assignments are provided in ⑨. The RJ45 connectors are internally connected.

Note: It is recommended that the remote override (On/Off) connections to be maintained for correct operation of these services across the C-Bus network, even if they are not intended to be used.

First Power Up

Managing the C-Bus Power Supply and C-Bus System Clock

By default, the integrated 200 mA C-Bus Power Supply is disabled. It can be enabled or disabled via the front panel and/or the SpaceLogic C-Bus Commission software.

By default, the C-Bus Clock Generator in the unit is disabled. It can be enabled or disabled via the front panel and/or the SpaceLogic C-Bus Commission software.

To Switch the Inbuilt C-Bus Power Supply and C-Bus System Clock if required:

Ensure adequate C-Bus power supply is enabled in the bus by referring to the indication on the unit and the bus design by checking the number of power supplies enabled. In case of low C-Bus power indication, switch the inbuilt C-Bus power supply in the relay.

Note: If the inbuilt switchable C-Bus power supply is enabled, the relay supplies power upto 200 mA to the network when connected to the mains.

Enabling/Disabling C-Bus Power Supply

By default, the integrated 200 mA C-Bus power supply is disabled. You can enable/disable the integrated C-Bus power supply via the front panel by performing a short press on the top right channel button whilst holding down the top left channel button to toggle the enabled state. Refer ③(a).

The enabled status of the integrated C-Bus power supply is shown on the unit indicator. Refer to diagnosis section (b). The C-Bus indicator light reflects the network voltage status. A flashing or off indicator signals that the network voltage is too low, indicating insufficient C-Bus power. In this case, you may need to enable additional power supplies.

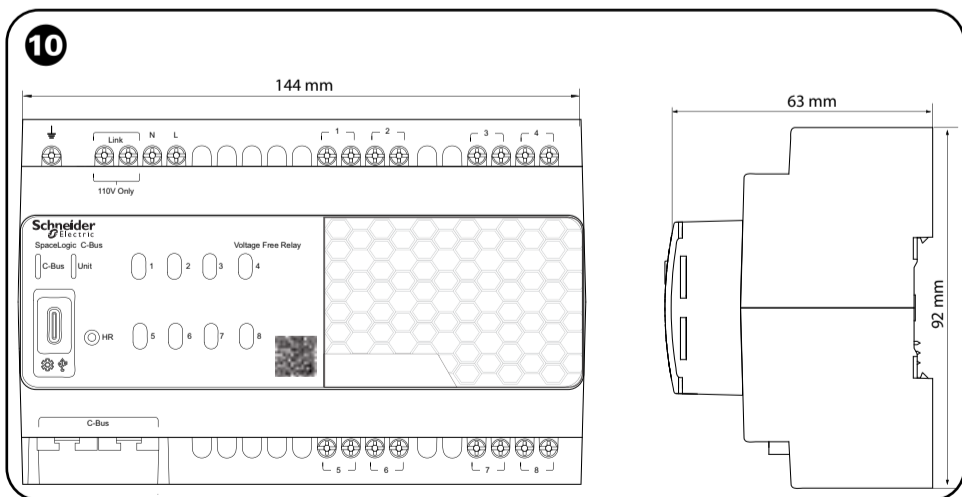
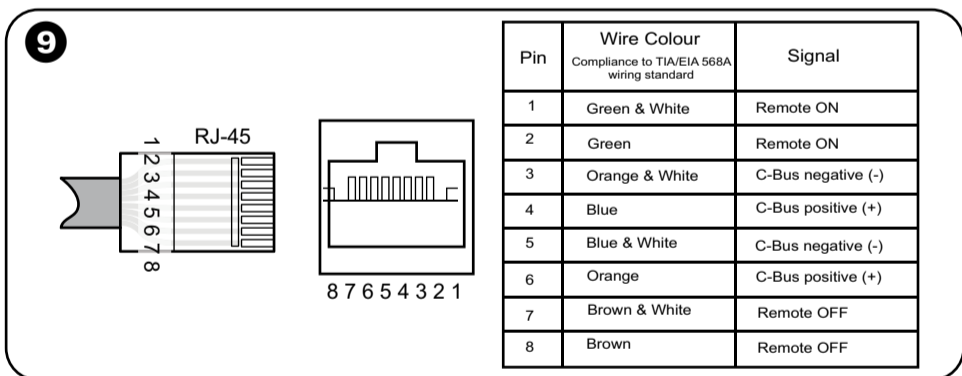
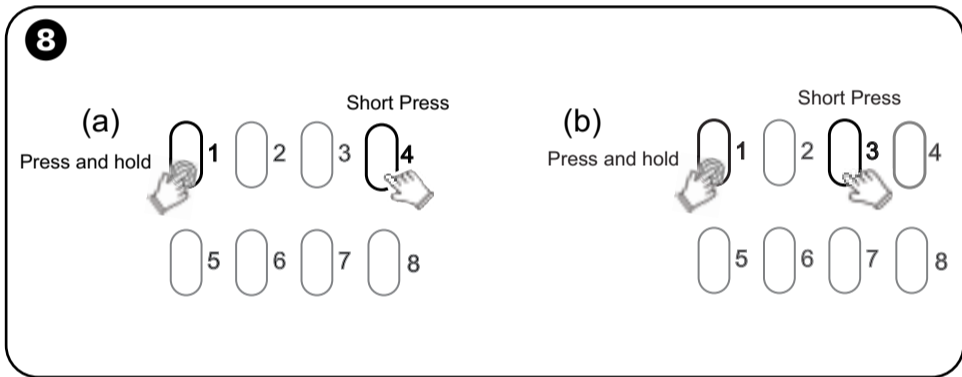
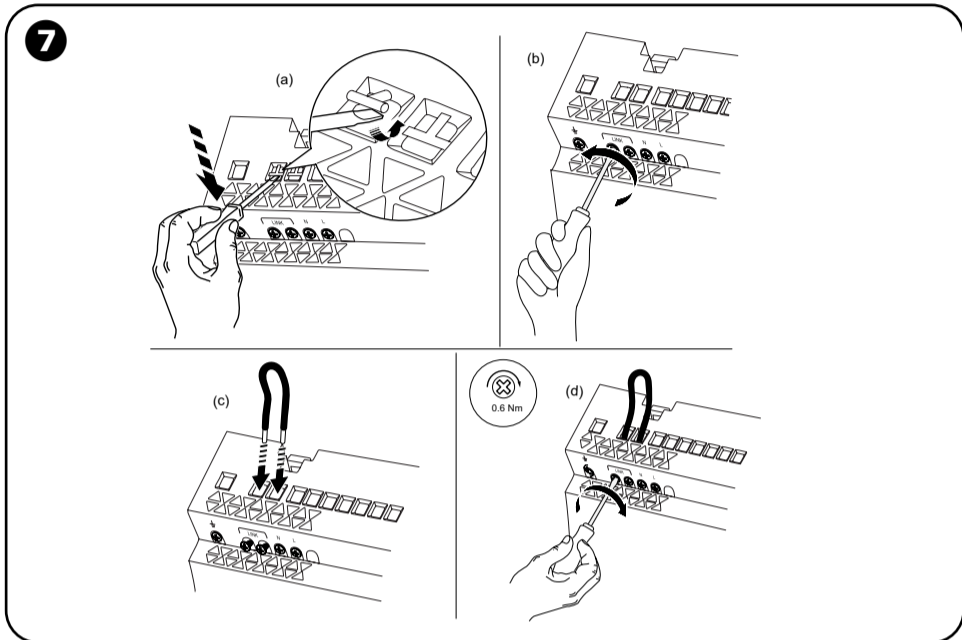
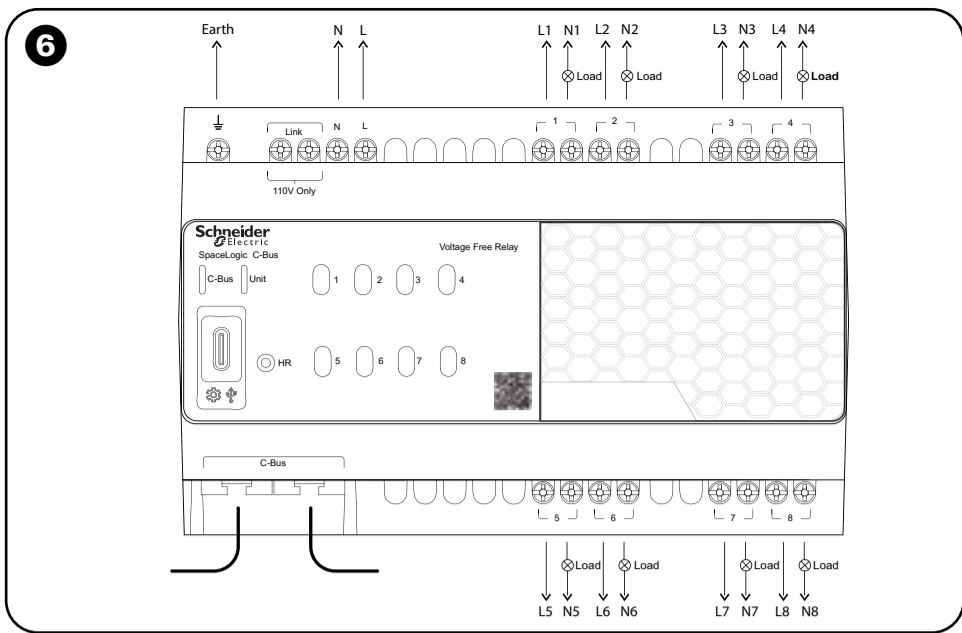

CAUTION
EQUIPMENT DAMAGE HAZARD
 It is important to ensure that no more than 2000 mA of total C-Bus Power Supply capacity is enabled/connected to any one C-Bus network. Ensure no more than 2000 mA of total C-Bus Power Supply is enabled/connected to any one C-Bus Network.
Failure to follow these instructions can result in injury or equipment damage.

Enabling/Disabling the C-Bus System Clock Generator (if required)
 By default, the C-Bus clock generator is disabled. The system clock is used to synchronize data communication over a C-Bus network. If a system clock is required, it can be enabled from the SpaceLogic C-Bus Commission software and the indicator buttons on the relay.
 You can enable/disable the integrated C-Bus clock generator via the front panel by performing a short press on the top second-to-right button whilst holding down the top left channel button to toggle the enabled state. Refer 3(b).

Configuration and Commissioning
 You configure and commission the unit through the C-Bus connection using the "SpaceLogic C-Bus Commission" software which can be downloaded from the URL: <http://www.se.com>
 You can power the unit by the USB Type-C connection to perform the configuration prior to the installation.

Local Override
 The channel indicator buttons on the front of the relay toggle the corresponding channel on and off, providing local override capability. Each button illuminates only when its respective channel is in the ON state. Local channel indicator buttons perform different functions depending on how they are pressed.

Operation	Function
Short-press	A single short press toggles the state of a channel.
Double-click	A double click will return particular channel to the C-Bus network level.
Long-press (> 2 seconds)	A long press on any of the channel will return all channels to the C-Bus Network level.

Note: Double-click and long-press functions will only occur if the unit/channel is already in override mode. By default, any C-Bus commands received by the relay will override local toggle changes. In this case, only the channel associated with the received commands will revert to the C-Bus network state. This option may be disabled in software, refer to "Priority of Operating Modes".

Remote Override
 The extra two pairs of the C-Bus network cable provide high priority override functions for most C-Bus output units. The Green & Green/White pair is used for the Remote ON function. The Brown & Brown/White pair is used for the Remote OFF function. Connecting either pair to the C-Bus negative pair activates the corresponding function. The SpaceLogic C-Bus Network Automation and Application Controllers provide facilities to control these overrides. If you use this function, ensure continuity of these pairs between all output units in the installation.
Note: You should also ensure that these pairs are not left unterminated during installation, as this may accidentally trigger the override functions.

Priority of Operating Modes
 The output status of a C-Bus DIN Rail Relay can be changed by:
 • Pressing a C-Bus button.
 • Activating any of the local toggle buttons (local override).
 • Using the remote override facility.
 The priority ranking of these actions is as follows:

Mode	Priority	Function
Remote OFF	1(highest)	All channels OFF
Remote ON	2	All channels ON
Local Override	3*	Toggles the channel
C-Bus Input Unit (Wall plates, PIR etc)	4*(lowest)	Controls the channel

Power-Up Load Status
 The relay has on-board non-volatile memory, which by default is used to store the operating state of each channel in case of power loss. On restoration of power, the relay waits approximately 5 s for power to stabilise before restoring the channel states.

Firmware Update
 The SpaceLogic C-Bus Commission software will notify if a firmware update is required. The update requires a connection to the USB Type-C connector on the relay and is performed using the SpaceLogic C-Bus Commission software. All required firmware files will be included and authenticated as part of the latest SpaceLogic C-Bus Commission software release. The reset button is provided only for recovery purposes and should not be pressed unless instructed. Detailed instructions for the update process are included with the SpaceLogic C-Bus Commission software.

Diagnosis

Indications and their meaning

a. Channel Indicators 3 (J)

State/colour	Meaning
Green	Channel is On
Off	Channel is Off
Red	Channel configuration error

b. Unit Indicators 3 (G)

State/colour	Meaning
Green	Unit powered, C-Bus power supply enabled
Yellow	Unit powered, C-Bus power supply disabled
Off	No power to device
Red	Unit Powered, Configuration Error
Slow Flash, Red/Green	Internal temperature has exceeded over-temperature threshold. C-Bus power supply enabled
Slow Flash, Red/Yellow	Internal temperature has exceeded over-temperature threshold. C-Bus power supply disabled
Green, Short Flash Red	Internal temperature has exceeded over-temperature threshold. Override Active, C-Bus power supply enabled
Yellow, Short Flash Red	Internal temperature has exceeded over-temperature threshold. Override Active, C-Bus power supply disabled
Green, Short Flash Off	Override active. C-Bus power supply enabled
Yellow, Short Flash Off	Override active. C-Bus power supply disabled
Fast Flash, Green	Secondary firmware update in progress

c. C-Bus Indicator 3 (F)

State/colour	Meaning
Solid (not flashing)	C-Bus voltage OK (>20 V)
Red	No C-Bus clock detected, Host Online
Green	C-Bus clock detected, Host Online
Yellow	C-Bus clock detected, Host Offline
Off	No C-Bus voltage present or unit not powered
Steady Flash	C-Bus Voltage marginal (15-20 V)
Short Flash	C-Bus Voltage critical (<15 V)

Specifications

Parameter	Description
Nominal Mains Voltage and Frequency	220-240 Vac, 50 Hz 100-120 Vac, 60 Hz
C-Bus Input Operating Voltage	20 - 36 Vdc
C-Bus Input Operating Current	20 mA
C-Bus Power Supply (if enabled)	200 mA at 27-35 Vdc
Load Rating	Refer 1
Compatible Loads	
Operating Temperature	-5 to 55 °C in accordance with "Derating"
Operating Humidity	10-95% RH
Dimensions (W×H×D)	144 × 92 × 63
Mains Terminals	Accommodates 2 x 2.5 mm ² or 1 x 4 mm ² Screw driver used for the terminal is Phillips PH1.
C-Bus connections	2 x RJ45 connectors
Product Compliance	CE UK CA
Relay Switching Parameters	
Inrush Current	Max. 800 A/200 μs Max. 165 A/20 ms
Mechanical Endurance	>3 × 10 ⁶ operations
Minimum Load	12 Vdc/100 mA
Maximum rate of operation	6 operations per minute
No user-serviceable parts inside.	

Read Full Device User Guide Online
 Scan the QR code® for complete information about the device including operation, configuration, troubleshooting and using the product with SpaceLogic C-Bus software.

Trademarks
 QR Code® is a registered trademark of DENSO WAVE INCORPORATED.

Schneider Electric Industries SAS
 If you have technical questions, please contact the Customer Care Centre in your country. se.com/contact

Warranty
 For Warranty information and service, visit se.com/contact

Declaration
 This product is in compliance with the applicable directive and standards. Declaration of conformity can be downloaded on: se.com/docs